

Figure 2.2 James Stirling, sketches for the Staatsgalerie in Stuttgart.

into the making of the building. Figures 2.3, 2.4, and 2.5 – which pertain to the Wallraf-Richartz Museum in Cologne and present a standard ground plan drawing, an abstracted top-down axonometric hard-line drawing and a sketch axonometric drawing of the scheme respectively – serve as examples of the various types of drawings. Models never played an important role in Stirling’s design processes (Stirling 1992) and, therefore, for the most part, their photographs are not prominent in representations of the projects.

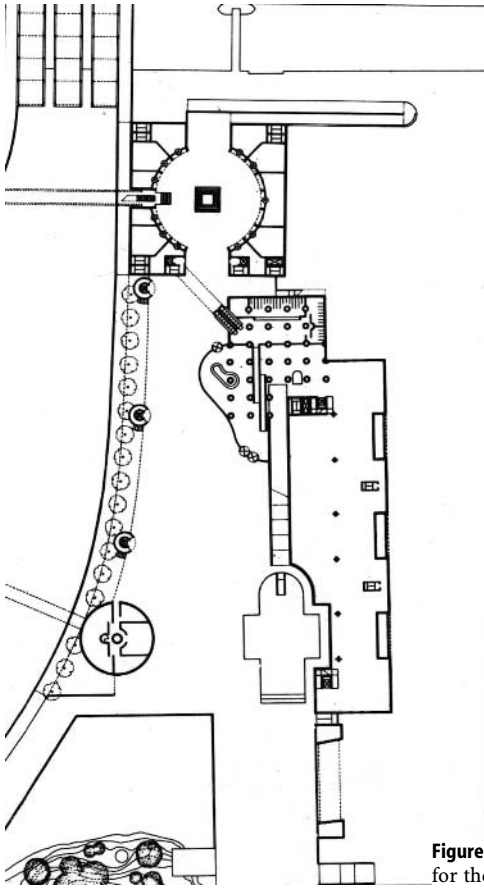

Figure 2.3 Drawing of the ground plan, project for the Wallraf-Richartz Museum in Cologne.

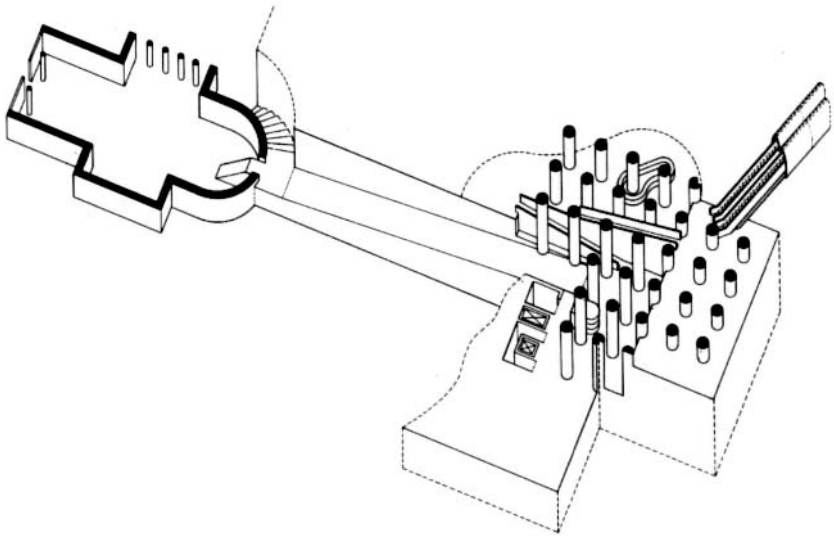

Figure 2.4 Top-down axonometric view of the Wallraf-Richartz Museum in Cologne.